

---

## 2.8 SUMMARY

- O The International Standards Organization created a model called the Open Systems Interconnection, which allows diverse systems to communicate.
- U The seven-layer OSI model provides guidelines for the development of universally compatible networking protocols.
- O The physical, data link, and network layers are the network support layers.
- O The session, presentation, and application layers are the user support layers.
- D The transport layer links the network support layers and the user support layers.
- O The physical layer coordinates the functions required to transmit a bit stream over a physical medium.
- O The data link layer is responsible for delivering data units from one station to the next without errors.
- O The network layer is responsible for the source-to-destination delivery of a packet across multiple network links.
- The transport layer is responsible for the process-to-process delivery of the entire message.
- D The session layer establishes, maintains, and synchronizes the interactions between communicating devices.
- U The presentation layer ensures interoperability between communicating devices through transformation of data into a mutually agreed upon format.
- O The application layer enables the users to access the network.
- TCP/IP is a five-layer hierarchical protocol suite developed before the OSI model.
- U The TCP/IP application layer is equivalent to the combined session, presentation, and application layers of the OSI model.
- U Four levels of addresses are used in an internet following the TCP/IP protocols: physical (link) addresses, logical (IP) addresses, port addresses, and specific addresses.
- O The physical address, also known as the link address, is the address of a node as defined by its LAN or WAN.
- The IP address uniquely defines a host on the Internet.
- The port address identifies a process on a host.
- O A specific address is a user-friendly address.

---

## 2.9 PRACTICE SET

### Review Questions

1. List the layers of the Internet model.
  1. The Internet model, as discussed in this chapter, include *physical*, *data link*, *network*, *transport*, and *application* layers.
- 
2. Which layers in the Internet model are the network support layers?
  2. The network support layers are the *physical*, *data link*, and *network* layers.
- 
3. Which layer in the Internet model is the user support layer?
  3. The *application* layer supports the user.
- 
4. What is the difference between network layer delivery and transport layer delivery?
  4. The *transport layer* is responsible for *process-to-process* delivery of the entire message, whereas the network layer oversees *host-to-host* delivery of individual packets.
- 
5. What is a peer-to-peer process?

5. *Peer-to-peer processes* are processes on two or more devices communicating at a same layer

---

6. How does information get passed from one layer to the next in the Internet model?

6. Each layer calls upon the *services* of the layer just below it using interfaces between each pair of adjacent layers.

---

7. What are headers and trailers, and how do they get added and removed?

7. *Headers* and *trailers* are control data added at the beginning and the end of each data unit at each layer of the sender and removed at the corresponding layers of the receiver. They provide source and destination addresses, synchronization points, information for error detection, etc.

---

8. What are the concerns of the physical layer in the Internet model?

8. The *physical layer* is responsible for transmitting a bit stream over a physical medium. It is concerned with

- physical characteristics of the media*
- representation of bits*
- type of encoding*
- synchronization of bits*
- transmission rate and mode*
- the way devices are connected with each other and to the links*

---

9. What are the responsibilities of the data link layer in the Internet model?

9. The *data link layer* is responsible for

- a. *framing data bits*
  - b. *providing the physical addresses of the sender/receiver*
  - c. *data rate control*
  - d. *detection and correction of damaged and lost frames*
- 

10. What are the responsibilities of the network layer in the Internet model?

10. The *network layer* is concerned with delivery of a packet across multiple networks; therefore its responsibilities include

- a. *providing host-to-host addressing*
  - b. *routing*
- 

11. What are the responsibilities of the transport layer in the Internet model?

11. The *transport layer* oversees the process-to-process delivery of the entire message. It is responsible for

- a. *dividing the message into manageable segments*
  - b. *reassembling it at the destination*
  - c. *flow and error control*
-

12. What is the difference between a port address, a logical address, and a physical address?

12. The *physical address* is the local address of a node; it is used by the data link layer to deliver data from one node to another within the same network. The *logical address* defines the sender and receiver at the network layer and is used to deliver messages across multiple networks. The port address (service-point) identifies the application process on the station.

---

13. Name some services provided by the application layer in the Internet model.

13. The *application layer services* include *file transfer*, *remote access*, *shared database management*, and *mail services*.

---

14. How do the layers of the Internet model correlate to the layers of the OSI model?

14. The *application*, *presentation*, and *session* layers of the OSI model are represented by the *application* layer in the Internet model. The lowest four layers of OSI correspond to the Internet model layers.

---

## Exercises

15. How are OSI and ISO related to each other?

15. The *International Standards Organization*, or the *International Organization of Standards*, (**ISO**) is a multinational body dedicated to worldwide agreement on international standards. An ISO standard that covers all aspects of network communications is the *Open Systems Interconnection* (**OSI**) model.

---

16. Match the following to one or more layers of the OSI model:

- a. Route determination
- b. Flow control
- c. Interface to transmission media
- d. Provides access for the end user

16.

- a. Route determination: *network* layer
- b. Flow control: *data link* and *transport* layers
- c. Interface to transmission media: *physical* layer
- d. Access for the end user: *application* layer

---

17. Match the following to one or more layers of the OSI model:

- a. Reliable process-to-process message delivery
- b. Route selection
- c. Defines frames
- d. Provides user services such as e-mail and file transfer
- e. Transmission of bit stream across physical medium

17.

- a. Reliable process-to-process delivery: *transport* layer
  - b. Route selection: *network* layer
  - c. Defining frames: *data link* layer
  - d. Providing user services: *application* layer
  - e. Transmission of bits across the medium: *physical* layer
-



8. Match the following to one or more layers of the OSI model:
- a. Communicates directly with user's application program
  - b. Error correction and retransmission
  - c. Mechanical, electrical, and functional interface
  - d. Responsibility for carrying frames between adjacent nodes

18.

- a. Communication with user's application program: *application* layer
  - b. Error correction and retransmission: *data link* and *transport* layers
  - c. Mechanical, electrical, and functional interface: *physical layer*
  - d. Responsibility for carrying frames between adjacent nodes: *data link* layer
- 

19. Match the following to one or more layers of the OSI model:

- a. Format and code conversion services
- b. Establishes, manages, and terminates sessions
- c. Ensures reliable transmission of data
- d. Log-in and log-out procedures
- e. Provides independence from differences in data representation

19.

- a. Format and code conversion services: *presentation* layer
  - b. Establishing, managing, and terminating sessions: *session* layer
  - c. Ensuring reliable transmission of data: *data link* and *transport* layers
  - d. Log-in and log-out procedures: *session* layer
  - e. Providing independence from different data representation: *presentation* layer
- 

20. In Figure 2.22, computer A sends a message to computer D via LAN1, router R1, and LAN2. Show the contents of the packets and frames at the network and data link layer for each hop interface.

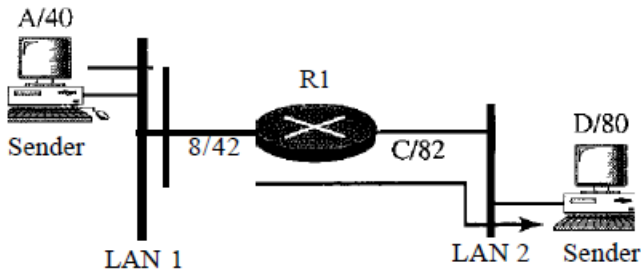

**Figure 2.1** Solution to Exercise 20

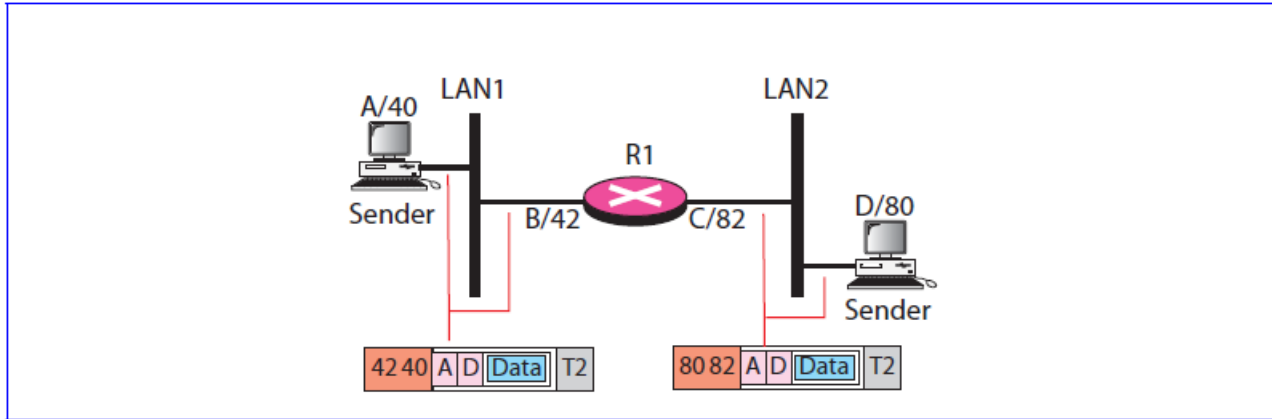

21. In Figure 2.22, assume that the communication is between a process running at computer A with port address  $i$  and a process running at computer D with port address  $j$ . Show the contents of packets and frames at the network, data link, and transport layer for each hop.



**Figure 2.2** *Solution to Exercise 21*

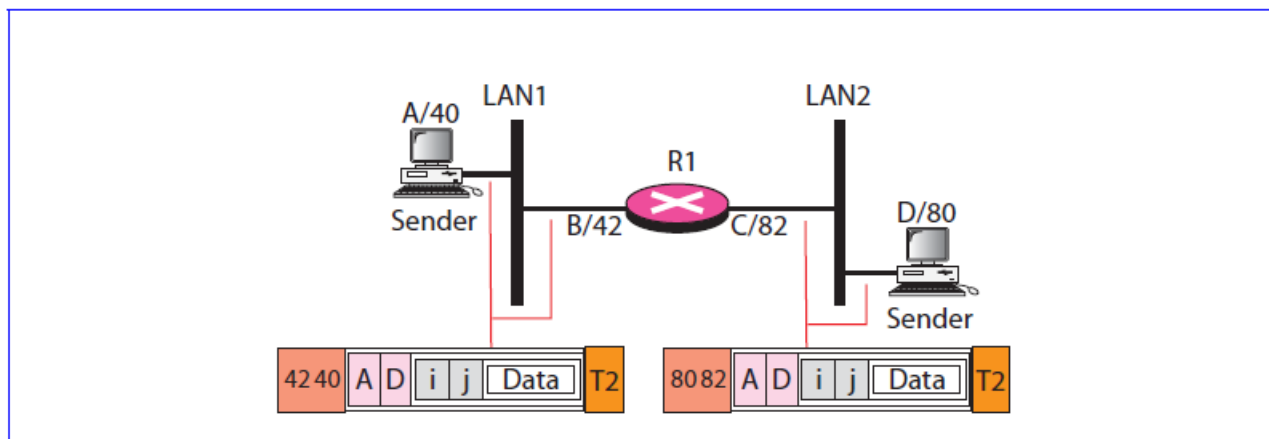

- 
22. Suppose a computer sends a frame to another computer on a bus topology LAN. The physical destination address of the frame is corrupted during the transmission. What happens to the frame? How can the sender be informed about the situation?
22. If the corrupted destination address does not match any station address in the network, the packet is lost. If the corrupted destination address matches one of the stations, the frame is delivered to the wrong station. In this case, however, the error detection mechanism, available in most data link protocols, will find the error and discard the frame. In both cases, the source will somehow be informed using one of the data link control mechanisms discussed in Chapter 11.
- 
23. Suppose a computer sends a packet at the network layer to another computer somewhere in the Internet. The logical destination address of the packet is corrupted. What happens to the packet? How can the source computer be informed of the situation?
23. Before using the destination address in an intermediate or the destination node, the packet goes through error checking that may help the node find the corruption (with a high probability) and discard the packet. Normally the upper layer protocol will inform the source to resend the packet.
-

24. Suppose a computer sends a packet at the transport layer to another computer somewhere in the Internet. There is no process with the destination port address running at the destination computer. What will happen?
24. Most protocols issue a *special error message* that is sent back to the source in this case.
25. If the data link layer can detect errors between hops, why do you think we need another checking mechanism at the transport layer?
25. The errors *between* the nodes can be detected by the data link layer control, but the error *at* the node (between input port and output port) of the node cannot be detected by the data link layer.
-